



**Gujarat Cooperative Milk Marketing Federation Ltd, Anand
AmulFed Dairy (Previously known as AmulFed Dairy)**

Plot No. 35, Nr. Indira Bridge,
Ahmedabad-Gandhinagar Highway
Village: Bhat, Dist: Gandhinagar
Gujarat, India-382428

Request for Bid (RFB) for "Design, Supply (FOR site basis including unloading), Installation, Testing & Commissioning of U -Straw Manufacturing machine including Bending and Individual Wrapping machine"as per given scope of work.

AFD: PUR: ENQ: 2020:153





AMULFED DAIRY

(A Unit of Gujarat Co-operative Milk Marketing Limited)
Plot No. 35, Near Indira Bridge, Ahmedabad-Gandhinagar Highway
Village - Bhat, Dist - Gandhinagar - 382428
Phone : +91-79-3969055/56 Fax : +91-79-3969059

We invite sealed bids from eligible bidders for the following works: **“Design, Supply (FOR site basis including unloading), Installation, Testing & Commissioning of U -Straw Manufacturing machine including Bending and Individual Wrapping machine”** as per the scope of supply mentioned in the Inquiry”.

Bid Reference	AFD: PUR: ENQ: 2020:153
Bid Start	Starts from 20.08.2020
Submission	Up to 02.00 pm of 17.09.202
Completion period	4 months

Eligibility Criteria

- 1) Bidder should be having minimum 1 number of successful installations of similar nature (Straw manufacturing machine with bending and packing/wrapping machine) working in India.
- 2) The Bidder/Supplier shall have turnover, in each of the last three years, at least **Rs. 20 crore** and must have executed, in the last three years at least one contract of similar nature.

Technical Specification : As per the Annexure-I

Submission of Bid :

Bidders fulfilling above eligibility criteria eligible for submission of bids in their name only.

- 1.1 The bid shall be submitted through hardcopy before above due date is acceptable.
- 1.2 The Price Break up sheet (in separate sealed Envelope) and technical document shall be submitted at the office address mentioned below.
- 1.3 The price Break up sheet should be entitled with reference of “Price Break Up for, **“Design, Supply, Installation and commissioning and Validation of U -Straw Manufacturing machine including Bending and Individual wrapping machine”**”.

Rights Reserved by AmulFed Dairy (A unit of GCMMF Ltd).

AmulFed Dairy (A unit of GCMMLtd), at its sole discretion and without assigning any reason thereof, reserves the right to accept and / or reject the whole or part of any or all the bids received.

Validity :

The offer should be valid for 6 Months from the date of Bid opening.

Contact details: For any techno-commercial query you may contact Palak Shah (7359001666), or (E-mail-palak.shah@amul.coop) of Purchase department.

Annexure-I

U -Straw Manufacturing machine including Bending and Individual Wrapping machine

Scope of Supply:

U-Straw Manufacturing Machine including:

- 1) High Speed Straw Manufacturing Machine including Autom Loader, Hopper Dryer, Chillers (Air Cooled Type), Anti Static Device, short straw collection parts etc.
- 2) Automatic Straw Bending Machine including interconnecting conveyors
- 3) U-Straw Packing Machine (Wrapping machine)
- 4) ZigZag/Mega Box Folder to pack straw chain to cartoon/CBX.
 - a. Bidder requested to provide optional price to pack carton of 1*1*1 mt in ZigZag/Mega Box Folder
- 5) Horizontal Perforation Device

Size of Straw: As per the below drawing

Minimum Output required : 700 Straw/hr.

Warranty should be Minimum-3 Years for machines

Spares for 3 years of smooth operation to provide

Supply, Installation, Commissioning and validation to be consider in the scope of supply.

Travel Expense, lodging Boarding, local transfers of Engineers till validation will be supplier's scope

SPECIFICATIONS FOR DRINKING STRAW

- Material : 100% of Polypropylene (Virgin Grade)
- Straw Tube Dia. : 4mm±0.2mm
- Straw Length : as per below drawings
- Upper length: 40mm±1mm
- Color : Milky white
- Packing Method :
- Individually wrapped "U-shaped straw" in OPP film
- with EZ-open, 18,000 straws to a master carton
- (1 carton=18,000 straws)
- Carton Size :
- 760mm X 690mm X 380mm (Approx.)

Straw Drawing-1:

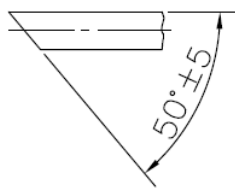
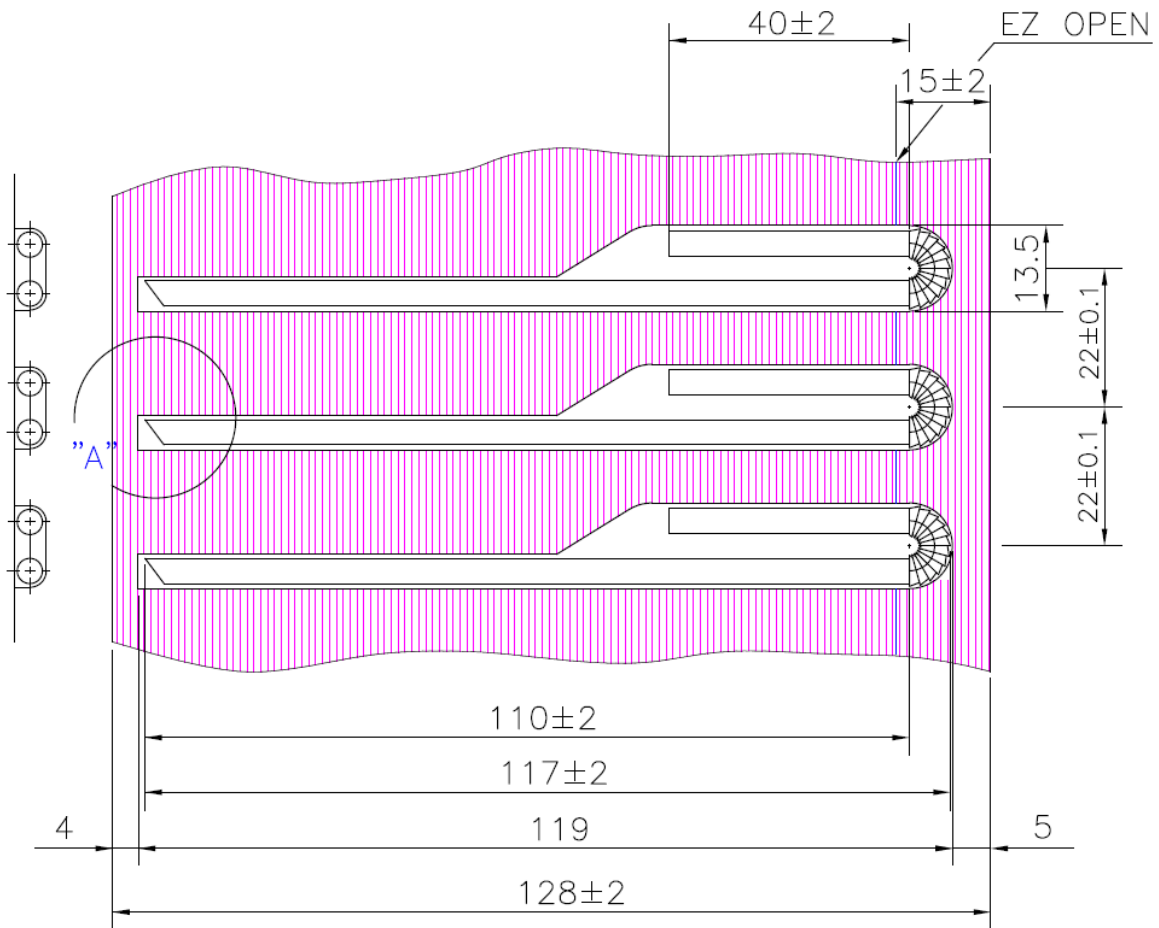

DETAIL "A"

NO.	DESCRIPTION	MATL	SIZE	Q'TY	REMARKS
DRAWN	CHECK		SCALE	DWG. NO.	
DESIGNED	APPROV		NS		
		MM	DATE		
		INCH			

Straw Drawing-2

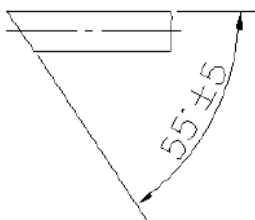
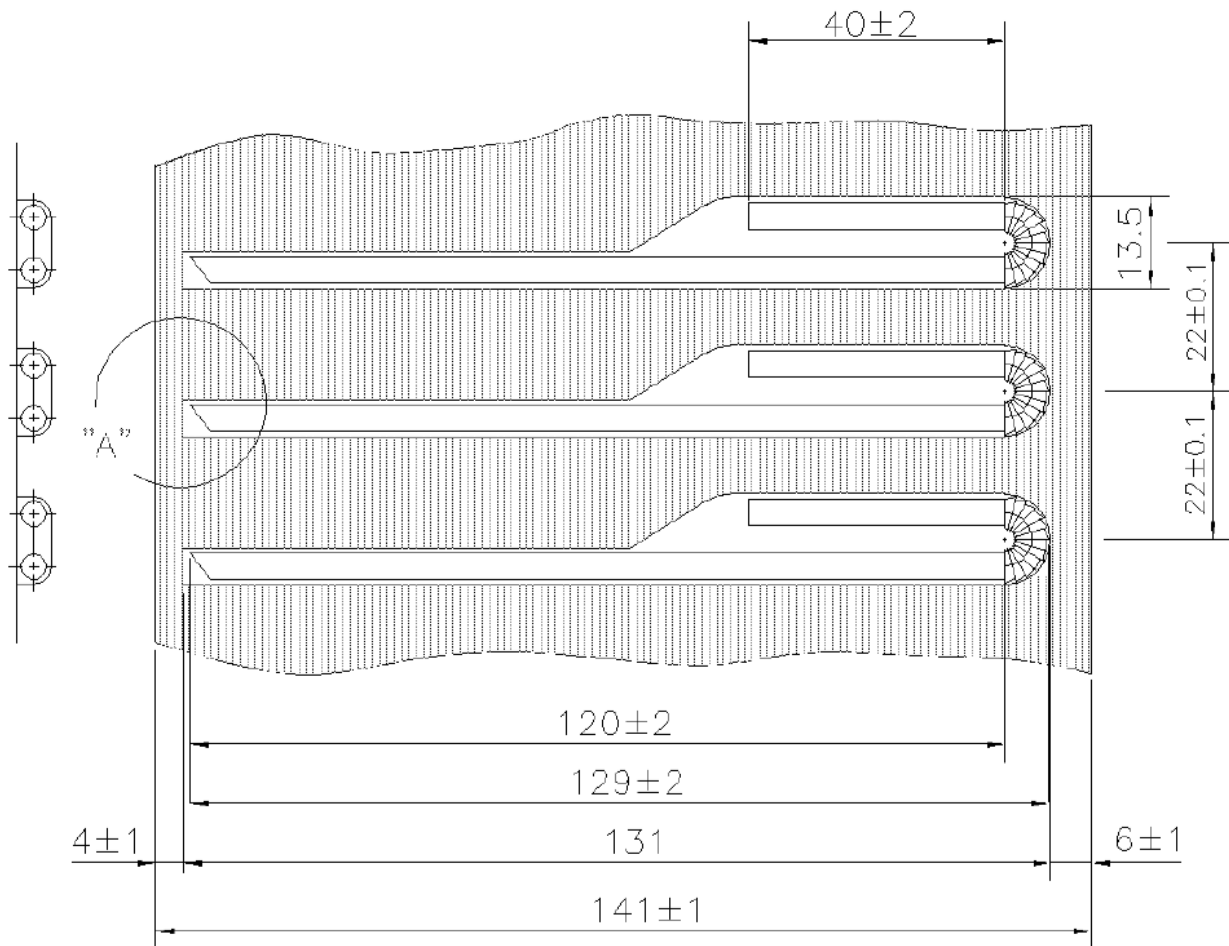

DETAIL "A"

NO.	DESCRIPTION	MATL	SIZE	Q'TY	REMARKS
	DRAWNED	CHECK	SCALE	DWG. NO.	
	DESIGNED	APPROV	MM INCH	DATE	

Annexure-IV

Price Schedule Form		
Summary Sheet		
SN	Summary Heads	Amount
1	2	3
1	Total Ex-factory, Packed	
2	Transportation	
3	Insurance	
4	GST/Custom Duty	
5	Total Supply Price delivered at Site (1+2+3+4)	
6	Total Installation & Commissioning with GST	
7	Total Bid Price (5+6)	

Note:

1	Bid must be submitted strictly as per this pro forma (items break-up sheet shall be submitted in hard copy in sealed envelope at office address mentioned in IFB with marking of "DO Not Open Before").
2	Amount against Sr. No 1 to 3 & 7 must be the total worked out in items break-up sheet.
3	Please quote charges for transportation (Sr. no 4) and insurance (Sr. no 5) as a percent of ex-factory, packed (Sr. No 1).
4	List of Spares with unit prices, valid for one year, must be submitted.
5	All the bidders have to submit price considering EPCG/MEIS as well as considering Full custom duty. In all the cases all the responsibility till commissioning of the plant will remain of Bidder/Supplier.

Signature of Authorized Signatory of Bidder/Supplier

Payment term for the tender:

Payment for supply, installation and commissioning contracts must be strictly as below:

- 1) 20% advance of total contract value (Supply + Erection & Commissioning) on submission of following:
 - (i) Acceptance of the order i.e.
 - a. Submission of the Duplicate copy of the order duly signed by the authorised signatory putting stamp of the Organisation.
 - b. Against a bank guarantee for equivalent amount valid for 60 days beyond the stipulated delivery (as per schedule of delivery/supply)/ completion period.
- 2) Payment against Supply and erection of equipments/material:
 - a. 65% progressive payment of supply value against safe receipt of goods at site.
 - b. 65 % payable on erection value on progression of erection within 30 days.
- 3) 15% balance payment within 30 days of satisfactory commissioning of the plant. On submission of:
 1. The Performance Security shall be in the amount of 15% of the Contract price up to sixty days after the date of completion of performance obligations including warranty obligations.

Notes: a) Payment shall be made on complete supply of an item/group of items specified in the contract. No payment specified in the contract. No payment shall be made if supply of an item/group of items is incomplete.

b) For all the payments to be made against bank guarantees, The Bank Guarantees should be obtained from Nationalized Bank or ICICI Bank, HDFC Bank, Yes Bank, IDBI Bank, Kotak Mahindra Bank or acceptable Bank by AFD.

Liquidated Damages

Bidder/Supplier fails to deliver any or all of the Goods or perform the Services within the time period(s) specified in the Contract, the Purchaser shall, without prejudice to its other remedies under the Contract, deduct from the Contract Price, as liquidated damages as under:

a. For the Supply Component:

A sum equivalent to 0.5% of the delivered price of the delayed goods (As per the price break up furnished by the supplier and accepted by the Purchaser, which the supplier fails to supply within the time period specified in the contract for each week of delay.

b. For the Erection and Commissioning Component:

A sum equivalent to 0.5% of the un – executed portion of each week of delay or part thereof beyond the time specified in the contract for the successful completion of the plant.

The total amount so deducted as per above, shall not exceed 5% of the Contract value. Once the maximum is reached, the Purchaser may consider termination of the Contract.

QUALIFICATION APPLICATION

Qualification Application Form

You must submit this form (Table 2 and 3), duly filled in, along with the supporting as per following checklist given in Table 1:

Table 1 Checklist for Supportings	
Supportings Required	Please (√)
Latest Balance sheet filed with (Name of Authority) on (Date)	
Latest Profit & Loss Statement from (date) to (date) filed with (Name of Authority) on (date).	
Audited copies ¹ of annual accounts and P & L account of past 3 years	
Certificate of Financial Soundness from Bankers of Bidder /Suppliers	
Income Tax Clearance Certificate (Latest)	
Sales Tax Clearance Certificate (Latest)	
Details of Income Tax Registration	
Details of Sales Tax Registration	
Organization Chart	
Annual Report of last three years	

¹ Indigenous Bidder/Suppliers must attach copy of accounts audited under section **44 AB of Income Tax Act**. In case the accounts need not be audited, a Chartered Accountant or Manager of a Nationalized Bank should attest the information in this statement.

**Table 2
Financial Soundness**

General Information		
Name		
Address		
Phones		
Mobile		
Fax		
E-mail		
Contact Personnel with designation		
Financial Information		
S N	Description	Value (Rs)
1	Cash Ba	In Bank
		In Hand
		Total
2	Fixed Assets	Gross
		Net
3	Current Assets	Inventories
		Others
		Total
4	Current liabilities	Bank Cash Credit
		Sundry creditors
		Others
		Provisions
		Contingent Liabilities (including claims not acknowledged, please specify)
		Total
5	Capital	Share capital

		Free reserves	
		Other reserves (please specify)	
6	Term loans from financial institutions and banks		
7	Working capital		
8	Net worth		
9	Debtors and advances considered good	More than 6 months	
		Less than 6 months	

Significant Financial Ratios			
SN	Ratio	Definition	Value
1	Current	Current Assets to Current Liabilities	
2	Acid Test	(Cash + temporary investment held in lieu of cash + current receivable) / current liabilities	
3	Solvency	Total Liability to Net Worth	
Net Profit before Tax			
SN	Period		Value
1	Current period		
2	During the last Financial Year		
3	During the year before last Financial Year		
Financial Arrangements			
SN	Resources		Amount
1	Own		
2	Bank Credits		
3	Others (Specify)		

Sales			
SN	Category of Customers	Value of orders to be executed/ anticipated Sales	
		Current	Next Financial Year
1	Government Department		
2	Commercial		
3	Others		
	Total		
Annual Turnover			
SN	Financial Year (Please begin with current year)		Turnover
1			
2			
3			
4			
5			
6			

**Table 3
Technical Competency**

Classifications		
SN	Category	Please (√)
1	Manufacturer	
2	Clearing & Forwarding Agent	
3	Stockist	
4	Wholesale Dealer	
5	Authorized Reseller	
6	Authorized Service Agent	
7	Retailer	
8	Trader	
9	Others (please specify)	
Details on Plant		
SN	Plant	Details
1	Location	
2	Description	
3	Type	
4	Size of building	
5	Is property on lease or free hold?	
6	If on lease, indicate date of expiry of lease in each case.	
7	Others (please specify)	

Plant Facilities					
SN	Facilities	Ans	Remark		
1	Space available for manufacturing (in m2)				
2	Space available for storage (in m2)				
3	Space available for inspection (in m2)				
4	Are buildings fire resistant? (Y/N)				
5	Are premises approved by Municipal fire Department? (Y/N)				
6	Are buildings under Municipal fire protection?				
7	Are power & fuel supply adequate to meet production requirements? (Y/N)				
8	Are adequate transportation facilities available? (Y/N)				
9	Are safety measures adequate for performance of proposed contract? (Y/N)				
10	Is adequate material handling equipment available? (Y/N)				
Testing Facilities					
SN	Facilities	Details			
1	List testing equipment available				
2	Give details of tests to be carried out on items offered.				
3	Details of the testing organizations available.				
Quality Control Organization					
SN	Quality Control Method	Response			
1	Are goods offered subject to Batch Test, Random Sampling or full 100% test for				
2	Are tests carried out by factory employees or by a separate testing agency?				
3	Are independent Quality Control Organization checks made and certificates				
Manufacturing Capacity					
SN	Description of Equipment	Capacity	Units Manufactured		
			Current year	Last Year	2nd last year
1					

2					
Personnel/ Organization					
SN	Personnel in	Numbers in levels			
		Managerial	Supervisory	Skilled Workmen	
1	Production				
2	Marketing				
3	Installation and commissioning				
4	Service				
5	Spare parts				
6	Administrative				
Service Center nearest to our site location					
Location					
Phone no					
SN	Information required on			Details	
1	Number of skilled employees				
2	Number of unskilled employees				
3	Number of engineering employees				
4	Number of administrative employees				
5	List of special repair/ workshop facility available				
6	The storage space available for spare parts (in m2)				
7	Value of minimum stock of spares available at all the service centres in respective currency				
8	List of the models/ types of equipment serviced by the Centre in last 2 years				

References ²						
SN	Name of Organization	Address, Telephone, Fax, Contact Person				
1						
2						
List of components usually subcontracted						
1						
2						
Workload for the current and forth coming financial year on quarterly basis						
SN	Financial Year	Quarterly Workload as % of Total Capacity				
		I	II	III	IV	
1	Current Financial Year					
2	Next Financial Year					
List of major projects of similar size and nature previously executed						
SN	Name of the client	Project	Year of award	Year of completion	Capacity/ Products	Value (Currency)
1						
2						
3						
4						
Type of equipment manufactured and supplied (M & S) during last 2 years						
SN	Equipment	Capacity	Qty	Projects	On Hand Order Qty	
1						
2						
3						
4						

² Names of two buyers to whom similar equipment are supplied, installed and commissioned in the past and to whom reference may be made by the AmulFed Dairy, Gandhinagar regarding the Bidder/Supplier's technical and delivery ability:

Type of equipment manufactured, supplied, installed and commissioned (MSIC)					
SN	Equipment	Capacity	Qty	Projects	On Hand Order Qty
1					
2					
3					
4					
Schedules for furnishing technical data and certified drawings after receipt of orders					
1					
2					
Number of weeks required for preparing a bid proposal					

Collaborators' Authorisation Form

Collaborators' Authorisation Form

Reference

Dated

General Manager

AmulFed Dairy, Gandhinagar

Plot No. 35, Near Indira Bridge

Ahmedabad - Gandhinagar Highway

Vill.: Bhat, Dist.: Gandhinagar - 382428

Gujarat, India

Dear Sir,

Bid Reference: MD/EXP/PKS/2015/1

We, (Name of the Collaborator), an established and reputable supplier of Technology and goods (Name of Technology & Goods) do hereby authorize (Name and address of **Agents**) to bid, negotiate and conclude the contract with you against Bid Reference: MD/EXP/PKS/2015/1 for the above technology & goods supplied by us.

No company or firm or individual other than (Name of your sole agent/ distributor) are authorized to bid, negotiate and conclude the contract in regard to this business against this specific Bid. (Strike out this, if not applicable)

We hereby extend our full guarantee and, warranty for the technology and goods offered for supply against this invitation for bid by the above firm.

Yours faithfully,

(NAME)

For and on behalf of

(Name of Manufacturers)

Note:

This letter of authority should be on the Letterhead of the Collaborators' concern and should be signed by a person competent and having the power of attorney to bind the Supplier.